



technowell

# Humidification Solutions

## Product Group

[technowell.com.tr](http://technowell.com.tr)

---

# Quality Meets Engineering

---

We offer humidity, temperature, and clean air solutions with energy efficiency in mind to enhance the comfort of indoor air that all living beings breathe.

---

We ensure quality and efficiency in production and storage areas with our climate control solutions.

---

**What is Humidity?** \_\_\_\_\_ **01**

**Steam Humidifier** \_\_\_\_\_ **02**

**OEM Steam Humidifier** \_\_\_\_\_ **11**

**Air Handling Unit High Pressure Humidifying Unit** \_\_\_\_\_ **19**

**Evaporative Humidifier** \_\_\_\_\_ **31**

**Ultrasonic Humidifier** \_\_\_\_\_ **37**

# What is Humidity?

**Absolute humidity** is described as the weight in grams of moisture found in 1 m<sup>3</sup> of air.

**Maximum humidity** refers to the amount of moisture that 1 m<sup>3</sup> air can carry at a given temperature. The amount of moisture that the air can carry increases as the temperature rises. In hot places, the maximum humidity is high, while in cold places it is low.

**Relative humidity** is defined as the ratio of absolute humidity to the maximum amount of humidity in the air. The relative humidity is expressed in percent (%).

The humidity gap in the air is eliminated when the relative humidity reaches 100%. This is referred to as saturated air.

The **humidity gap** is the difference between absolute humidity and maximum humidity in the air. The lower the humidity gap, the higher the relative humidity.

# Steam Humidifier

TSH series units are steam humidifiers with electrodes used to humidify the air duct or air handling unit cell.

The steam is channelled through the stainless steel distributor into the air duct or air handling unit. It can be easily assembled. It can be used by hanging on the switchboard or the ground. It is sufficient to connect the water inlet connection, the water drainage line connection, the steam and distribution connection, the electrical wiring and the humidity sensor connection and to put the steam humidification unit into operation.

Auto humidification is accomplished thanks to the smart humidity and power control system. Humidification systems from the TSH series can be used on air handling units that don't have humidity control. The humidity sensor signal required for humidity control is provided by the air handling unit manufacturer's control panel.





## Humidifier Casing

It is made of galvanized sheet electrostatically powder-coated.



## Automatic Water Level Control

It automatically adjusts water consumption according to the steam output.



## Steam Cylinder

Technowell steam cylinder is an essential component of steam humidification units. The steam cylinder accumulates deposits produced during the steam process, which can be easily cleaned. Steam cylinders that have reached the end of their useful life can be quickly replaced to ensure reliable humidity control.

Due to their advanced conductivity management and use of current-regulated electrodes, steam cylinders can operate precisely.



## Digital Display Control Panel

User interface with MODBUS protocol provides detailed operational control.



## Drain Valve

An automatic and effective drain valve that minimizes water loss.



# Functional Description

The Technowell TSH steam humidifier is a non-pressure steam generator using electrode heating.

This unit is designed for air humidification through a steam distributor (steam distribution pipe, external fan unit).



## Steam Production

Electrodes with high electrical conductivity and long working life are contained inside the steam cylinder. The electrodes are supplied with current settings as the device needs steam. The inlet valve opens at the same time, causing water to enter the steam cylinder from below through the water chamber and feed line.

When the electrodes come into contact with water, a current begins to flow between the electrodes, eventually heating and vaporizing the water.

The more water that comes into contact with the electrode surface, the higher the current consumption and therefore the steam capacity. The inlet valve closes when the desired steam capacity is reached. The inlet valve opens until the necessary capacity is restored if the steam generation falls below a certain capacity or a certain percentage due to the lowering of the water level (e.g. due to evaporation or evacuation).

If the required steam output is less than the actual output, the inlet valve is closed until the desired output is reached by lowering the water level (evaporation process).



## Level Monitoring

When the water level rises, a sensor in the steam cylinder cover detects it. The inlet valve closes when the sensor comes into contact with water.



## Evacuation

The increased mineral content caused by the evaporation process increases the conductivity of water. Eventually, if this concentration mechanism is allowed to proceed, an unacceptably high current consumption would result. To prevent this concentration from reaching a value unsuitable for the process, a certain amount of water is periodically drained from the cylinder and replaced by water. The water hardness to be used should be in the range of 10 ° - 40 ° f (CaCO<sub>3</sub> equal to 400 ppm), the water conductivity should be in the range of 75 - 1250 μS/cm.



## Control

Steam production, humidity control or On/Off control can be done via MODBUS communication.

- Automatic water filling and drainage in the unit
- Automatic cleaning based on working conditions
- Water level alert
- High and low current alert
- Drainage alert
- Fault alert
- Remote control with RS 485 protocol
- 0-10V, 0-20 mA, 4-20 mA, On-Off
- Supply power 220V - 50 HZ / 12 VDC 20 W
- Output power 220 VAC 50 Hz
- 0 °C - 50 °C operating conditions
- 20% RH - 90% RH humidity conditions

# Steam Humidifier Accessories

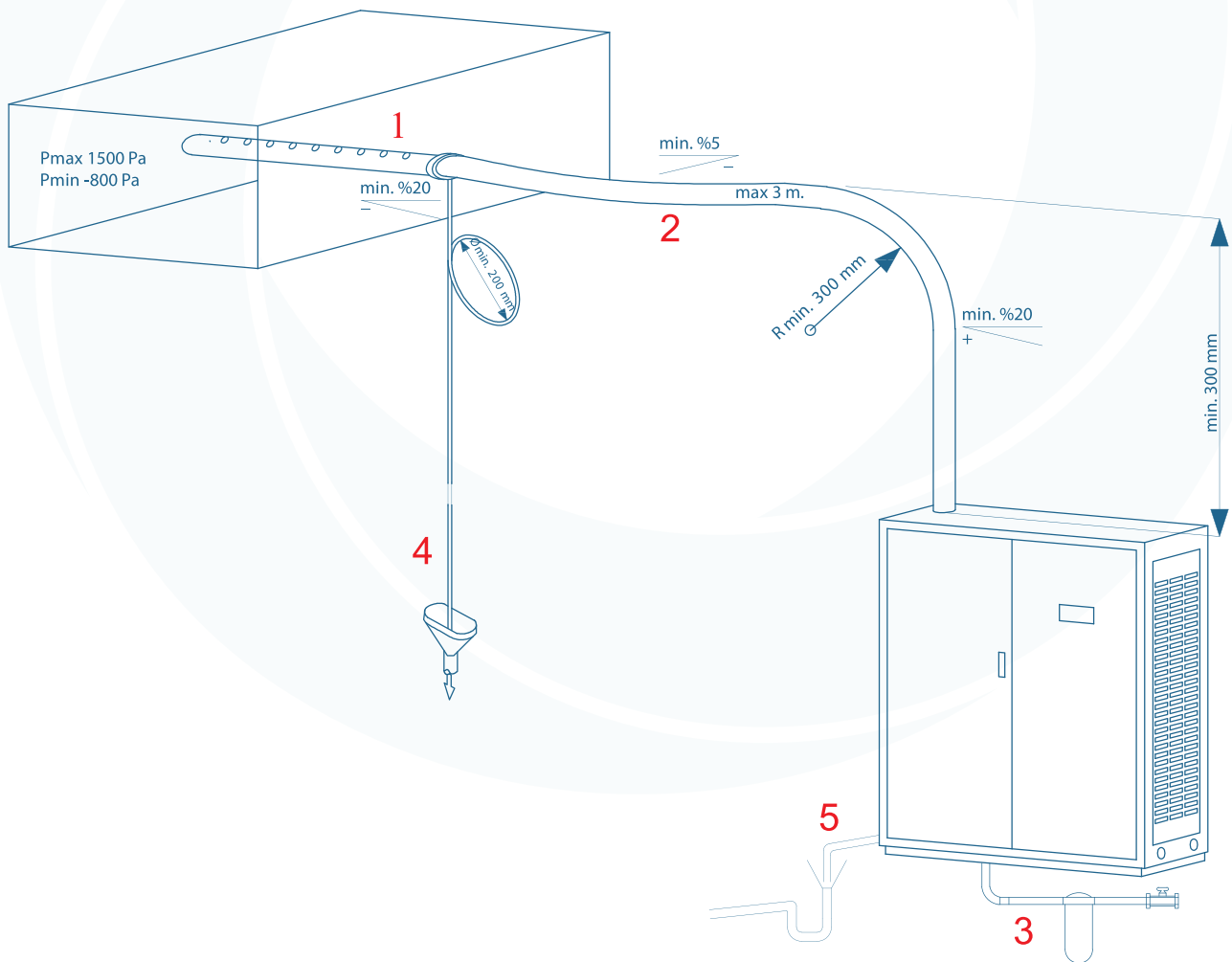

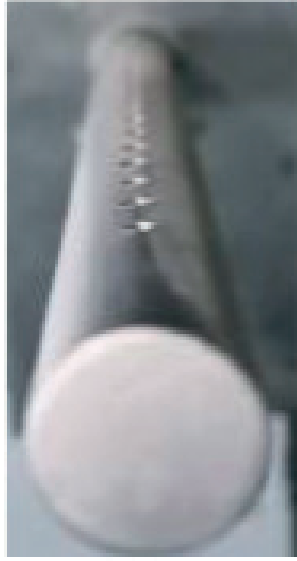

## Steam distribution diffuser for air duct or air handling unit humidification cell installation

It ensures that the steam obtained from the steam humidifier is distributed homogeneously in the air duct or air handling unit humidifier. The steam distribution diffuser is made of stainless steel material. The steam distribution diffuser is chosen based on the steam humidifier's capacity and the channel width for horizontal installation or the channel height for vertical installation.



## Steam distribution hose

It provides the steam obtained in the steam cylinder to enter the steam distribution diffuser. Long-lasting and free of toxic materials, the steam distribution hose is made of special medical rubber that can withstand temperatures of up to 120 °C. The length of the steam delivery hose should be no more than 3 meters. The bend radius of the steam distribution hose must be at least  $r=300$  mm, with an upward slope of 20% or a downward slope of 5%.

3



## Water inlet hose

The steam humidifier's water inlet hose was manufactured specifically for it. One connection end is made of G 3/4 "plastic and the other side is made of G 1/2" copper material. The hose is made of a durable rubber material.

4



## Condensate drain hose

The condensate drain hose is made of plastic that can withstand high temperatures. Its structure is pliable. The condensate drain hose is shaped into a siphon and guided to the discharge funnel with a minimum inclination of 20% (minimum hose bending diameter Ø200mm).

5



## Drainage hose

It is used to remove water from the steam cylinder that has risen in mineral concentration as a result of the evaporation process.

MODEL	TSH-4	TSH-8	TSH-15	TSH-30
STEAM CAPACITY	0,8 - 5,0 kg/h	1,6 - 13,0 kg/h	3,0 - 18,0 kg/h	6,0 - 35,0 kg/h
POWER SUPPLY	380 V -50 Hz	380 V -50 Hz	380 V -50 Hz	380 V -50 Hz
OPERATION CURRENT	1-6A	2-15A	3,5-20A	6,8-39A
RATED POWER	0,60 -3,75 kW	1,20 -9,75 kW	2,25 -13,50 kW	4,50 -26,25 kW
STEAM OUTLET	1xØ 30mm	1xØ 30mm	1xØ 30mm	1xØ 30mm
WATER TANK QUANTITY	1	1	1	1
WORKING CONDITIONS	1 °C - 40 °C %10 - % 90 RH	1 °C - 40 °C %10 - % 90 RH	1 °C - 40 °C %10 - % 90 RH	1 °C - 40 °C %10 - % 90 RH
STORAGE CONDITIONS	1 °C - 70 °C %5 - % 95 RH	1 °C - 70 °C %5 - % 95 RH	1 °C - 70 °C %5 - % 95 RH	1 °C - 70 °C %5 - % 95 RH
WATER INLET CONNECTION	G 1/2"	G 1/2"	G 1/2"	G 1/2"
WATER INLET TEMPERATURE	1 °C - 40 °C	1 °C - 40 °C	1 °C - 40 °C	1 °C - 40 °C
WATER INLET PRESSURE	1 - 8 bar	1 - 8 bar	1 - 8 bar	1 - 8 bar
DRAINAGE FLOWRATE	1,2 lt/min	1,2 lt/min	1,2 lt/min	1,2 lt/min
WATER HARDNESS	15 -40 F°s	15 -40 F°s	15 -40 F°s	15 -40 F°s
WATER CONDUCTIVITY	125 -1250 µS/cm	125 -1250 µS/cm	125 -1250 µS/cm	125 -1250 µS/cm
DRAINAGE TEMPERATURE	≤ 100 °C	≤ 100 °C	≤ 100 °C	≤ 100 °C
DRAINAGE PIPE CONNECTION	Ø 22mm / Ø 30mm	Ø 22mm / Ø 30mm	Ø 22mm / Ø 30mm	Ø 22mm / Ø 30mm
DIMENSIONS (A X B X C)	410x565x320 mm	410x565x320 mm	465x670x320 mm	620x810x430 mm

**MODEL****TSH-42 TSH-60 TSH-84 TSH-120**STEAM  
CAPACITY

8 -45 kg/h 12 -70 kg/h 16 -90 kg/h 25 -140 kg/h

## POWER SUPPLY

380 V -50 Hz 380 V -50 Hz 380 V -50 Hz 380 V -50 Hz

OPERATION  
CURRENT

9 -51 A 2x6,8 A -2x39 A 2x9 A -2x51 A 3x9 A -3x51 A

## RATED POWER

6,00 -33,75 kW 9,00 -52,50 kW 12,00 -67,50 kW 18,75 -105 kW

## STEAM OUTLET

1xØ 30mm 2xØ 30 mm 2xØ 30 mm 3xØ 30mm

WATER TANK  
QUANTITY

1 2 2 3

WORKING  
CONDITIONS1°C - 40 °C  
%10 - % 90 RH 1°C - 40 °C  
%10 - % 90 RH 1°C - 40 °C  
%10 - % 90 RH 1°C - 40 °C  
%10 - % 90 RHSTORAGE  
CONDITIONS1°C - 70 °C  
%5 - % 95 RH 1°C - 70 °C  
%5 - % 95 RH 1°C - 70 °C  
%5 - % 95 RH 1°C - 70 °C  
%5 - % 95 RHWATER INLET  
CONNECTION

G 1/2" G 1/2" G 1/2" G 1/2"

WATER INLET  
TEMPERATURE

1°C - 40 °C 1°C - 40 °C 1°C - 40 °C 1°C - 40 °C

WATER INLET  
PRESSURE

1 - 8 bar 1 - 8 bar 1 - 8 bar 1 - 8 bar

DRAINAGE  
FLOWRATE

4 lt/min 2x4 lt/min 2x4 lt/min 3x4 lt/min

## WATER HARDNESS

15 -40 F°s 15 -40 F°s 15 -40 F°s 15 -40 F°s

WATER  
CONDUCTIVITY

300 -1250 µS/cm 300 -1250 µS/cm 300 -1250 µS/cm 300 -1250 µS/cm

DRAINAGE  
TEMPERATURE

≤ 100 °C ≤ 100 °C ≤ 100 °C ≤ 100 °C

DRAINAGE  
PIPE CONNECTION

Ø 22mm / Ø 30mm Ø22mm / Ø 30mm Ø22mm / Ø 30mm Ø 22mm / Ø 30mm

DIMENSIONS  
(A X B X C)

620x810x430 mm 1000x810x430 mm 1000x810x430 mm 1390x810x430 mm

# OEM Steam Humidifier

TSH series are electrode steam humidification units used for humidifying air ducts or air handling unit cells.

Steam is directed into the air duct or air handling unit through a stainless steel distributor. It is easy to install and can be used either suspended from the unit or placed on the floor. To operate the device, simply connect the water inlet, water drainage line, steam and distributor connections, electrical wiring and humidity sensor connections. The device will then perform automatic humidification via to its smart humidity and capacity control system.

TSH series humidification units can be used with air handling units that do not have built-in humidity control. The necessary humidity sensor signal for humidity control is obtained from the control panel of the air handling unit manufacturer.



# OEM STEAM HUMIDIFIER

## Accessories



### Coated Outer Sheet Metal

Carrier panel made from corrosion-resistant painted sheet metal



### Drain Valve

An automatic and effective drain valve that minimizes water loss



### Steam Cylinder

Technowell steam cylinder is an essential component of steam humidification units. The steam cylinder accumulates deposits produced during the steam process, which can be easily cleaned. Steam cylinders that have reached the end of their useful life can be quickly replaced to ensure reliable humidity control.

Due to their advanced conductivity management and use of current-regulated electrodes, steam cylinders can operate precisely.



# Functional Description

The Technowell TSH steam humidifier is a non-pressure steam generator using electrode heating.

This unit is designed for air humidification through a steam distributor (steam distribution pipe, external fan unit).



## Steam Production

Electrodes with high electrical conductivity and long working life are contained inside the steam cylinder. The electrodes are supplied with current settings as the device needs steam. The inlet valve opens at the same time, causing water to enter the steam cylinder from below through the water chamber and feed line.

When the electrodes come into contact with water, a current begins to flow between the electrodes, eventually heating and vaporizing the water.

The more water that comes into contact with the electrode surface, the higher the current consumption and therefore the steam capacity. The inlet valve closes when the desired steam capacity is reached. The inlet valve opens until the necessary capacity is restored if the steam generation falls below a certain capacity or a certain percentage due to the lowering of the water level (e.g. due to evaporation or evacuation).

If the required steam output is less than the actual output, the inlet valve is closed until the desired output is reached by lowering the water level (evaporation process).



## Level Monitoring

When the water level rises, a sensor in the steam cylinder cover detects it. The inlet valve closes when the sensor comes into contact with water.



## Evacuation

The increased mineral content caused by the evaporation process increases the conductivity of water. Eventually, if this concentration mechanism is allowed to proceed, an unacceptably high current consumption would result. To prevent this concentration from reaching a value unsuitable for the process, a certain amount of water is periodically drained from the cylinder and replaced by water. The water hardness to be used should be in the range of 10 ° - 40 ° f (CaCO<sub>3</sub> equal to 400 ppm), the water conductivity should be in the range of 75 - 1250 µS/cm.



## Control

Steam production, humidity control or On/Off control can be done via MODBUS communication.

- Automatic water filling and drainage in the unit
- Automatic cleaning based on working conditions
- Water level alert
- Fault Warning
- Remote control with RS 485 protocol
- 0-10V, 0-20 mA, 4-20 mA, On-Off
- Supply power 380V
- Output power 220V - 12VDC
- 0 °C - 50 °C operating conditions
- %20 RH - %90 RH humidity conditions



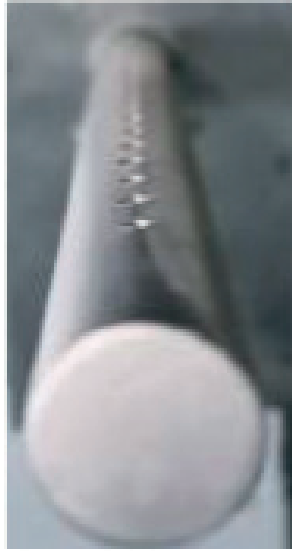

## Steam distribution diffuser for air duct or air handling unit humidification cell installation

It ensures that the steam obtained from the steam humidifier is distributed homogeneously in the air duct or air handling unit humidifier. The steam distribution diffuser is made of stainless steel material. The steam distribution diffuser is chosen based on the steam humidifier's capacity and the channel width for horizontal installation or the channel height for vertical installation.



## Steam distribution hose

It provides the steam obtained in the steam cylinder to enter the steam distribution diffuser. Long-lasting and free of toxic materials, the steam distribution hose is made of special medical rubber that can withstand temperatures of up to 120 °C. The length of the steam delivery hose should be no more than 3 meters. The bend radius of the steam distribution hose must be at least  $r = 300$  mm, with an upward slope of 20% or a downward slope of 5%.

3



## Water inlet hose

The steam humidifier's water inlet hose was manufactured specifically for it. One connection end is made of G 3/4 "plastic and the other side is made of G 1/2" copper material. The hose is made of a durable rubber material.

4



## Condensate drain hose

The condensate drain hose is made of plastic that can withstand high temperatures. Its structure is pliable. The condensate drain hose is shaped into a siphon and guided to the discharge funnel with a minimum inclination of 20% (minimum hose bending diameter Ø200mm).

5



## Drainage hose

It is used to remove water from the steam cylinder that has risen in mineral concentration as a result of the evaporation process.

**MODEL****OEM TSH-4****OEM TSH-8****OEM TSH-15****OEM TSH-30****OEM TSH-42**STEAM  
CAPACITY

0,8 - 5,0 kg/h

1,6 - 13,0 kg/h

3,0 - 18,0 kg/h

6,0 - 35,0 kg/h

8,0 - 45,0 kg/h

## POWER SUPPLY

380 V -50 Hz

380 V -50 Hz

380 V -50 Hz

380 V -50 Hz

380 V -50 Hz

OPERATION  
CURRENT

1 - 6 A

2 - 12 A

3,5 - 20 A

6,8 - 39 A

9 - 51 A

## RATED POWER

0,60 -3,75 kW

1,20 -9,75 kW

2,25 -13,50 kW

4,50 -26,25 kW

6,00 -33,75 kW

## STEAM OUTLET

1xØ 30mm

1xØ 30mm

1xØ 30mm

1xØ 30mm

1xØ 30mm

WATER TANK  
QUANTITY

1

1

1

1

1

WORKING  
CONDITIONS1°C - 40 °C  
%10 - % 90 RH1°C - 40 °C  
%10 - % 90 RH1°C - 40 °C  
%10 - % 90 RH1°C - 40 °C  
%10 - % 90 RH1°C - 40 °C  
%10 - % 90 RHSTORAGE  
CONDITIONS1°C - 70 °C  
%5 - % 95 RH1°C - 70 °C  
%5 - % 95 RH1°C - 70 °C  
%5 - % 95 RH1°C - 70 °C  
%5 - % 95 RH1°C - 70 °C  
%5 - % 95 RHWATER INLET  
CONNECTION

G 1/2"

G 1/2"

G 1/2"

G 1/2"

G 1/2"

WATER INLET  
TEMPERATURE

1°C - 40 °C

1°C - 40 °C

1°C - 40 °C

1°C - 40 °C

1°C - 40 °C

WATER INLET  
PRESSURE

1 - 6 bar

1 - 6 bar

1 - 6 bar

1 - 6 bar

1 - 6 bar

DRAINAGE  
FLOWRATE

1,2 lt/min

1,2 lt/min

1,2 lt/min

1,2 lt/min

1,2 lt/min

## WATER HARDNESS

15 -40 F°s

15 -40 F°s

15 -40 F°s

15 -40 F°s

15 -40 F°s

WATER  
CONDUCTIVITY

350 -1250 µS/cm

350 -1250 µS/cm

350 -1250 µS/cm

350 -1250 µS/cm

350 -1250 µS/cm

DRAINAGE  
TEMPERATURE

≤ 100 °C

≤ 100 °C

≤ 100 °C

≤ 100 °C

≤ 100 °C

DRAINAGE  
PIPE CONNECTION

Ø 22mm / Ø 30mm

Ø22mm / Ø 30mm

Ø22mm / Ø 30mm

Ø 22mm / Ø 30mm

Ø 22mm / Ø 30mm

DIMENSIONS  
(A X B X C)

295x515x265 mm

295x515x265 mm

318x720x280 mm

447x805x380 mm

447x805x380 mm

\*OEM TSH-60/84/120 options are available. The OEM TSH-60/84 models come with 2 steam tanks and 2 steam outlets, while the OEM TSH-120 model features 3 steam tanks and 3 steam outlets.

\*The control board is included.



## **exploration, implementation, after-sales services**

With our engineering approach, we provide the right climate control products and solutions aimed at efficiency, continuity, and sustainability across various industries such as textiles, automotive, chemicals, pharmaceuticals, electronics and semiconductors, and food storage.

# Air Handling Unit High Pressure Humidifying Unit

The adiabatic or the other name evaporative humidification is performed by the high-pressure humidification unit, which is one of the product types used to satisfy the humidification need in the air handling unit.

The aim is to raise the relative and absolute humidity of the environment fed by the air handling unit. There are solutions such as steam, honeycomb and high pressure humidification to meet this need

In several ways, a high-pressure humidifier outperforms other methods of humidification. When efficiency, particle size, electricity consumption, and return on investment are considered, it is the preferred method.

Two main units make up the air handling unit's high-pressure humidification unit;



**High-Pressure Pump Station**



**Humidification Unit**

# High-Pressure Pump Station

There is a high-pressure pump at the pump station, selected according to the capacity of the air handling unit. Depending on the capacity, the number of pumps can vary. An electrical panel for the unit, an inverter for capacity control, a solenoid valve, water filters, and an optional touchscreen control panel are all found on this station. This station, which is located between the humidification unit and the network line, is the outdoor unit of the humidification system.

All humidification systems use Danfoss PAH series high-pressure pumps. The pump's most notable features are its long service life (roughly 40,000 hours) and oil-free operation. It works without oil, so there's no need to add oil or substitute felt during maintenance. It's made entirely of stainless steel and the maintenance is very easy.

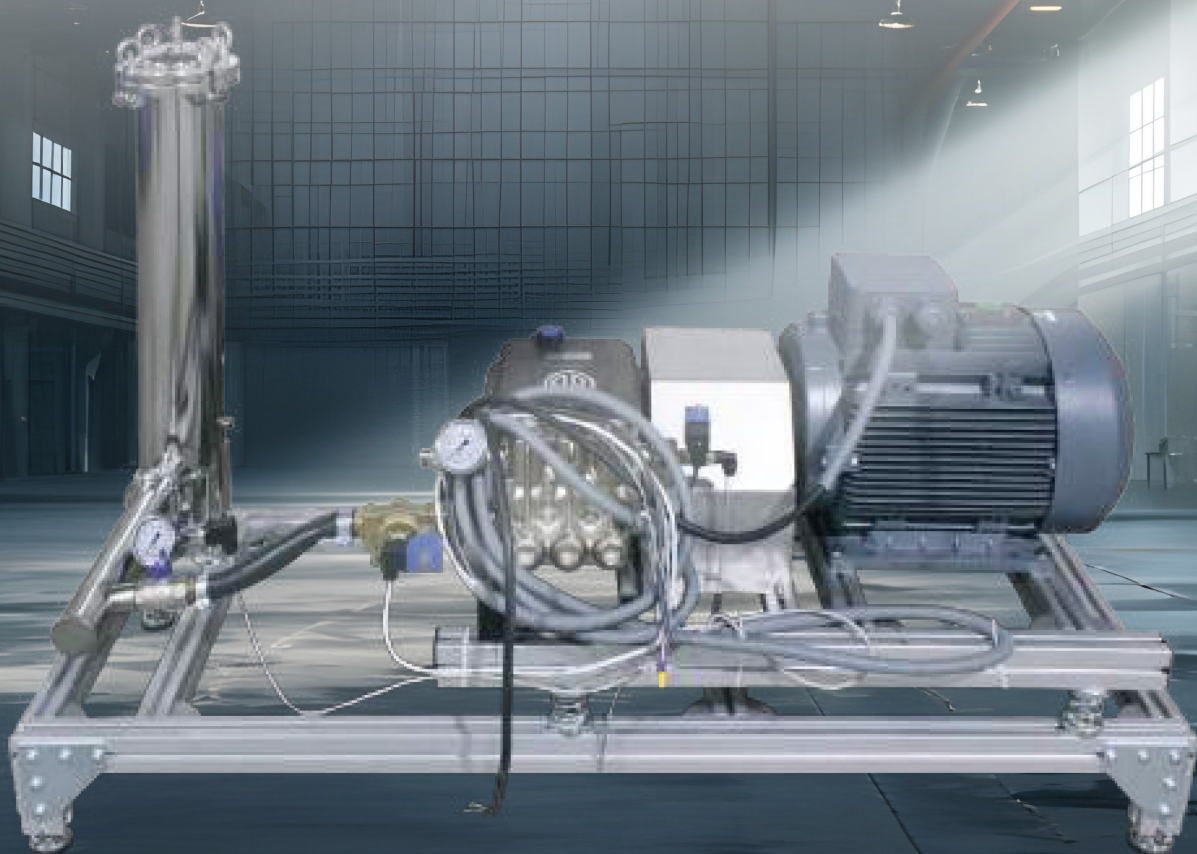

# High-Pressure Pump Station

## MODEL

## PAH 2.0 PAH 4.0 PAH 6.3 PAH 10 PAH 12.5

BODY MATERIAL

AISI 304 AISI 304 AISI 304 AISI 304 AISI 304

GEOMETRIC  
DISPLACEMENT

2 cm<sup>3</sup>/dev 4 cm<sup>3</sup>/dev 6,3 cm<sup>3</sup>/dev 10 cm<sup>3</sup>/dev 12,5 cm<sup>3</sup>/dev

MIN. OUTLET  
PRESSURE

30 bar 30 bar 30 bar 30 bar 30 bar

MAX. OUTLET  
PRESSURE

140 bar 140 bar 140 bar 160 bar 160 bar

MAINS PRESSURE

0 -4 bar 0 -4 bar 0 -4 bar 0 -4 bar 0 -4 bar

MIN. REVOLUTIONS  
PER MINUTE

700 d/d 700 d/d 700 d/d 700 d/d 700 d/d

MAX. REVOLUTIONS  
PER MINUTE

1800 d/d 1800 d/d 1800 d/d 1800 d/d 1800 d/d

CAPACITY

2 lt/min 5,2 lt/min 8,7 lt/min 13,4 lt/min 17,2 lt/min

ELECTRIC ENGINE

0,90kW 1,70 kW 2,60 kW 4,50 kW 5,60 kW

SOUND LEVEL

76 dB(A) 76 dB(A) 76 dB(A) 75 dB(A) 75 dB(A)

WEIGHT

4,40 kg 4,40 kg 4,40 kg 7,70 kg 7,70 kg

NOTE

The values given for the capacity and electric motor are specified for 1500 rpm.  
Request information for higher capacity models.

*Danfoss*

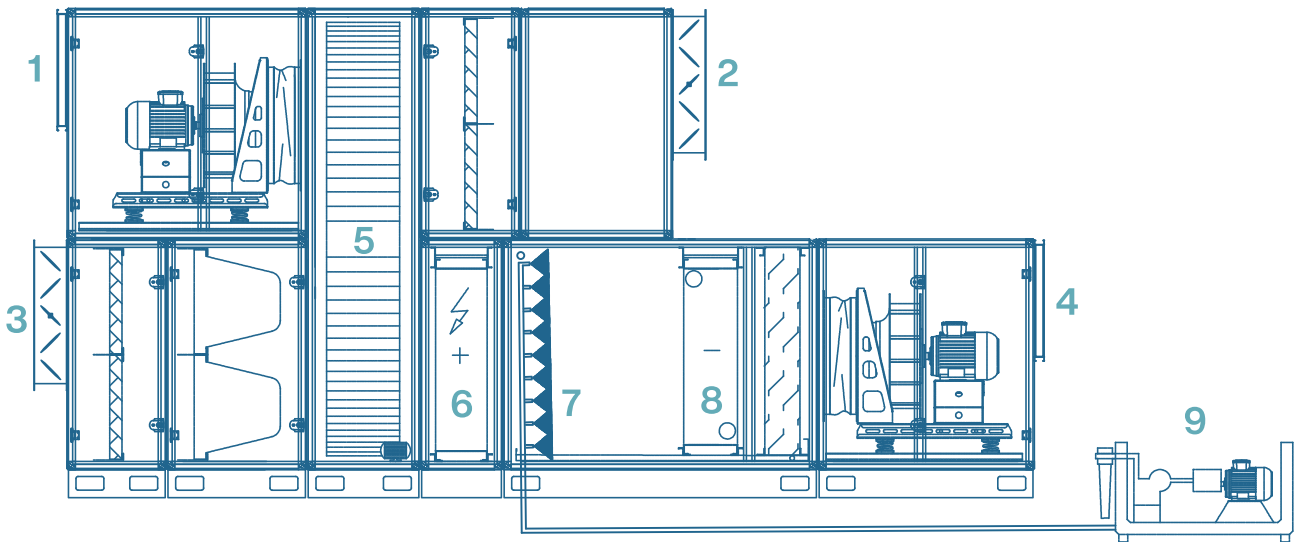

- ① Inside Air Exhaust
- ② Inside Air Suction
- ③ Fresh Air Inlate
- ④ Inside Air Outlet
- ⑤ Rotary Type Heat Recovery Unit

- ⑥ Heating Coil
- ⑦ High-Pressure Nozzle System
- ⑧ Cooling Coil *Drop eliminator according to air velocity at empty cross-section*
- ⑨ High-Pressure Pump Unit

# PERFORMANCE CURVES OF PUMPS

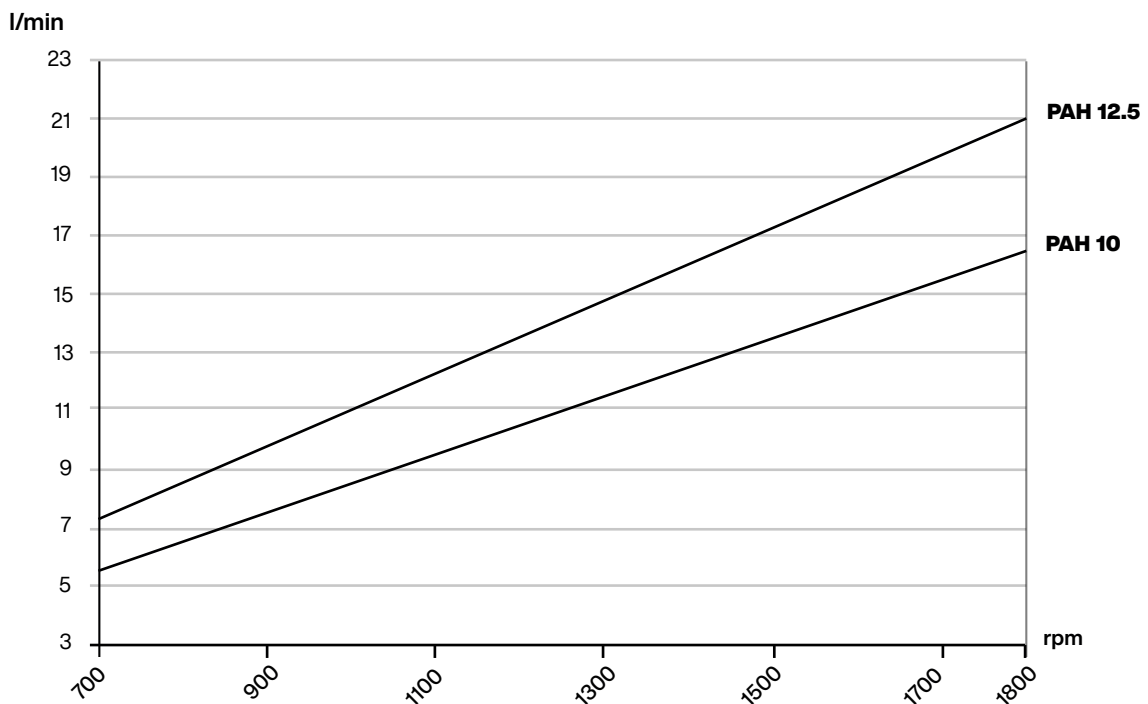
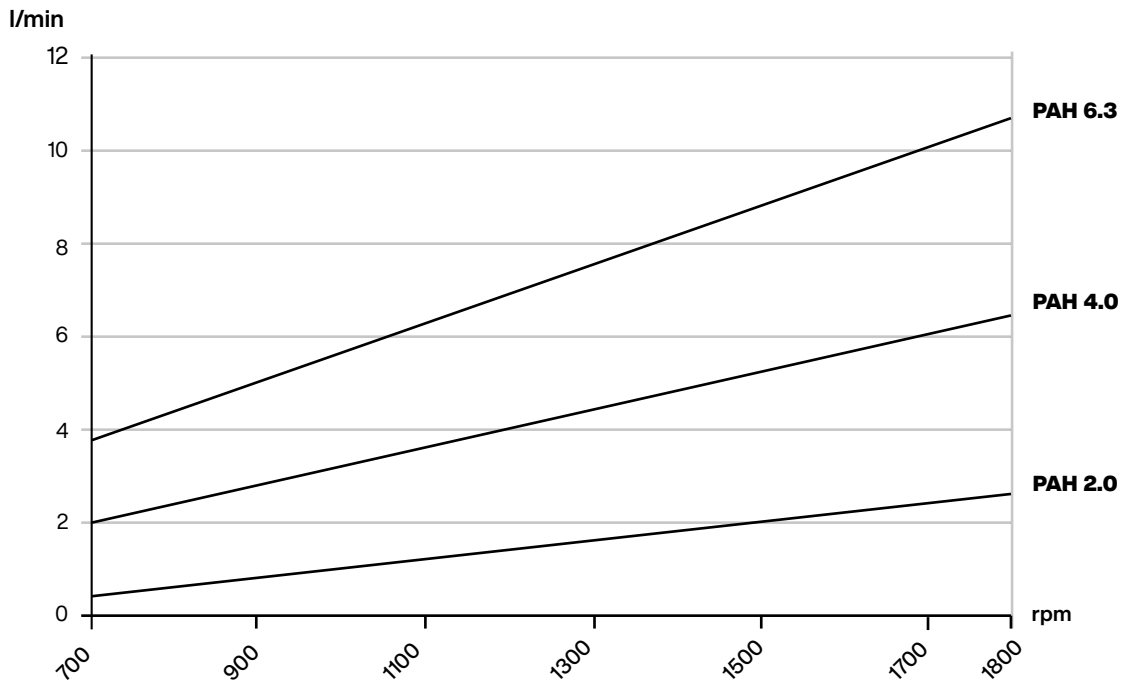

# Humidification Unit

There are stainless steel nozzles and pipes on the humidification unit, which are determined according to the capacity. To ensure homogeneous humidification, the distances between the nozzle and the pipe are computed specifically based on the cross-sectional areas provided by the plant manufacturer. Total capacity varies depending on the air handling unit's air-flow rate and the desired humidity conditions. To determine the pump model and calculate capacity, the following information is needed:

- Air Handling Unit Air Volume (m<sup>3</sup>/h)
- Inlet Air Dry Bulb Temperature (°C)
- Inlet Air Relative Humidity (%RH)
- Desired Outlet Air Dry Bulb Temperature (°C)
- Desired Outlet Air Relative Humidity (%RH)

The nozzle, frame and pipes used are all stainless steel. Although there are nozzle options with appropriate diameters for various capacities, their numbers are determined for a uniform distribution based on the air handling unit's flow rate and cross-sectional area. To increase the nozzle capacity of a cell with a very high flow rate and a small cross-section, a nozzle with a large hole diameter is used.



# Capacity Selection and Automation

To make it easier to choose, air handling unit manufacturers use precise cross-sectional dimensions for specific air-flow speeds. The table below shows the units and capacities chosen as averages based on these air-flow rates and air handling unit cross-sectional dimensions.

NOZZLE CAPACITIES				
NOZZLE DIAMETER	0,15 mm	0,20 mm	0,30 mm	0,50 mm
70 BAR CAPACITY	2,90 lt/h	4,30 lt/h	6,90 lt/h	13,00 lt/h
80 BAR CAPACITY	3,10 lt/h	4,70 lt/h	7,40 lt/h	14,00 lt/h
100 BAR CAPACITY	3,50 lt/h	5,30 lt/h	8,30 lt/h	15,60 lt/h

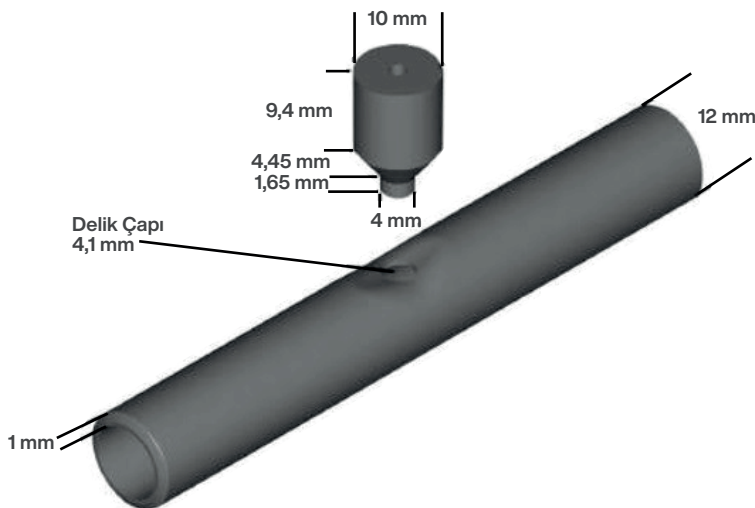

# EXAMPLE

## CAPACITY SELECTION

MODEL	POWER PLANT CELL INTERNAL SECTION	AIR VOLUME	PUMP MODEL	HUMIDIFICATION MODEL CAPACITY
ACHP-2	1220 x 1530 mm	15000 m <sup>3</sup> /h	PAH 2.0	72 kg/h
ACHP-2	1220 x 2140 mm	22000 m <sup>3</sup> /h	PAH 2.0	106 kg/h
ACHP-4	1530 x 2140 mm	28000 m <sup>3</sup> /h	PAH 4.0	135 kg/h
ACHP-4	1530 x 3060 mm	40000 m <sup>3</sup> /h	PAH 4.0	192 kg/h
ACHP-4	1830 x 3060 mm	50000 m <sup>3</sup> /h	PAH 4.0	240 kg/h
ACHP-4	2140 x 3360 mm	60000 m <sup>3</sup> /h	PAH 4.0	288 kg/h
ACHP-6.3	2140 x 4280 mm	70000 m <sup>3</sup> /h	PAH 6.3	336 kg/h
ACHP-6.3	2440 x 3670 mm	80000 m <sup>3</sup> /h	PAH 6.3	384 kg/h
ACHP-6.3	2440 x 3670 mm	80000 m <sup>3</sup> /h	PAH 6.3	384 kg/h
ACHP-6.3	2440 x 4590 mm	100000 m <sup>3</sup> /h	PAH 6.3	480 kg/h
CAPACITY SELECTION CONDITION	<b>Entry Requirement</b>	35 °C - %20 RH		
	<b>Exit Condition</b>	25 °C - %60 RH		
NOTE	The capacities have been chosen based on the flow rate and cross-section dimensions of the air handling unit. The values in the table are not exact and reflect the average values of the above-mentioned climatic conditions.			

Different scenarios can be used if automation is requested. The humidification unit can be monitored and controlled remotely. The pump can be driven with an inverter or used as On-Off. In the humidification unit, precise control can be achieved. Using solenoid valves, the humidification unit is divided into compartments for gradual control application, and each compartment can be controlled independently.

## Automation Scenarios

**On-Off:** At a constant pressure of 80 bar, all nozzles in the humidification unit open at the same time and deliver moisture to the air handling unit cell. When the necessary humidity is present in the indoor climate, the system shuts down automatically.

**Gradual Control:** The humidification unit's nozzles are divided into four main zones, with the 1st mainline providing a continuous capacity of at least 25%. The required moisture requirement is met with gradual control by opening the 2.-3.-4. mainline, in case of need.

## Air Turbulator

In order for the air to be sufficiently saturated with moisture when a high-pressure humidification unit is used in a standard air handling unit, a minimum cell with a length of approximately 1.80 - 2.00 m is needed. As a result, increasing the cell size raises the costs. Productivity starts to decline as the cell size shrinks. Intense water drainage is observed before the drop eliminator as a result of water drift. Even if the power plant manufacturer produces a suitable length power plant for this unit, there would not be enough room to position it in the field. In this case, air diverters are used, which are entirely manufactured and designed by the Technowell Engineering group.

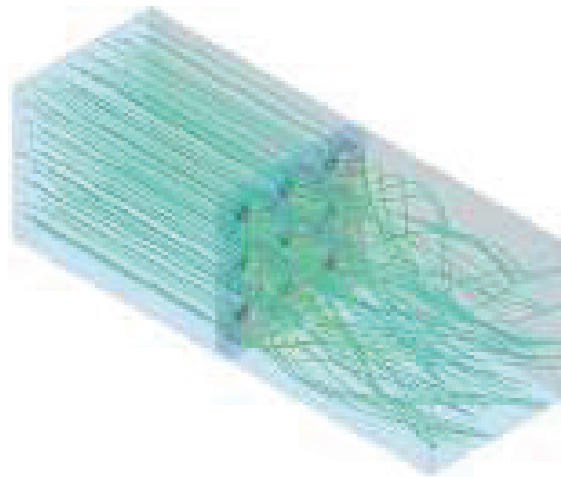

## Water Quality

There are two filters on the pump station to filter the water taken from the mains line and sent to the pump. Filters should be closely followed and replaced according to a predetermined procedure to ensure pump health and productive humidification. To control internal leakage and improve component performance, Danfoss PAH series pumps have a very narrow dead space design.

A 10  $\mu\text{m}$  absolute filter with a beta value of  $\beta_{10} \geq 5.000$  and an efficiency rate of 99.98% is used as the main filter. This filter is efficient enough that it only allows 20 particles out of 100,000 to pass through.



## High-Pressure Humidification and Psychrometric Diagram

In high-pressure humidification processes, there is no audible heating or cooling. Since the moisture released into the environment has a small enough particle size to blend with the air, evaporation is facilitated, and the environment naturally cools. The enthalpy remains constant in the process since there is no sensible heating or cooling. After the humidification process, the temperature decreases. As moisture is provided to the atmosphere, absolute humidity rises. Depending on the absolute humidity, the relative humidity also increases.

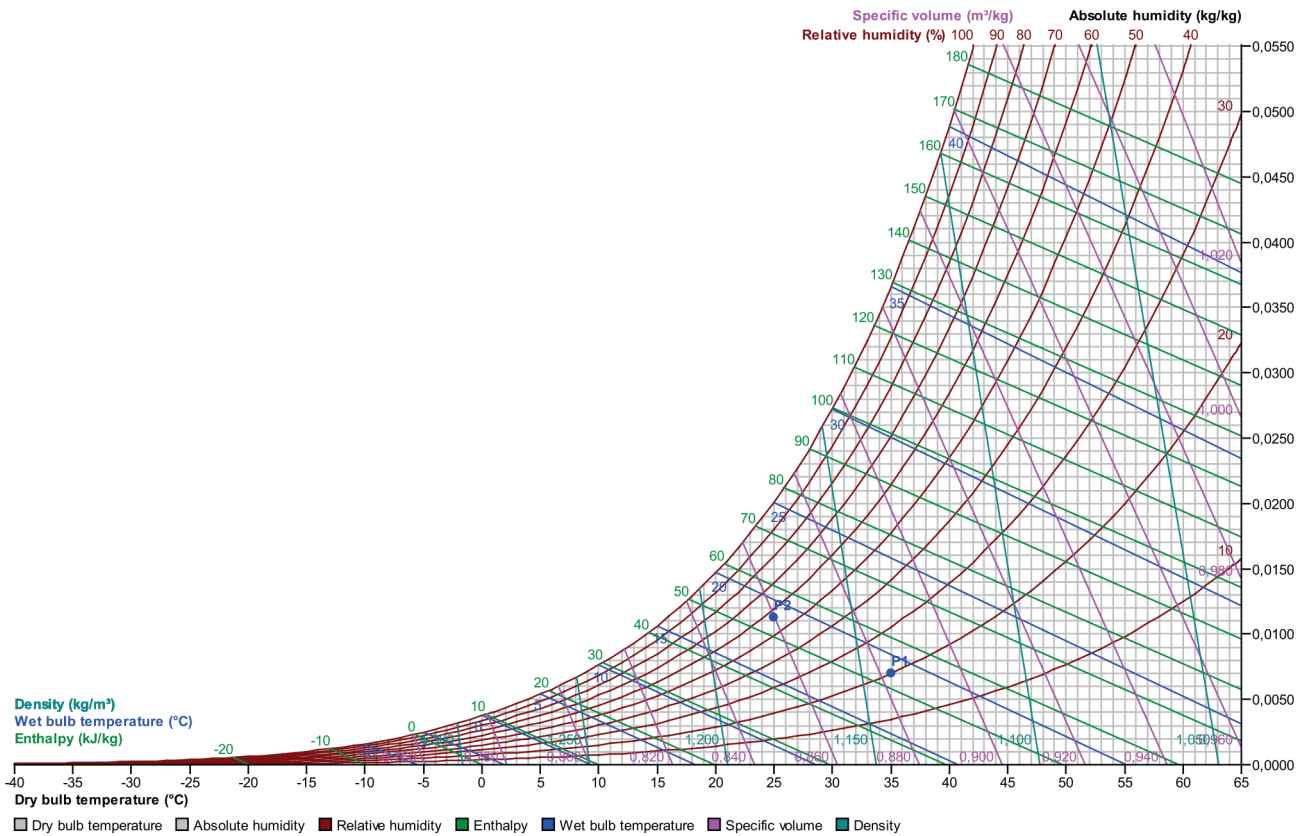

## Electricity Saving and Efficiency

Because of its high efficiency and low energy usage, a high-pressure humidification unit is favored over a steam humidifier. The pump station's electric motors use very little energy because instead of heating the water, it pulverizes it with a 0.2 mm nozzle at high pressure. But the temperature drops after the high-pressure humidification process. Extra preheating can be needed if temperature and humidity are significant in the system. As compared to a steam humidifier, the high-pressure humidifier has a self-compensation duration of about 4 months.

**SYSTEM OPERATING CONDITIONS AND GENERAL INFORMATION**

MAINS WATER PRICE	1,5768 \$/m <sup>3</sup>
ELECTRICITY PRICE	0,0939 \$/kWh
SYSTEM DAILY WORKING HOURS	18

**TECHNICAL DATA BEFORE HIGH-PRESSURE HUMIDIFICATION UNIT**

SYSTEM ELECTRICITY CONSUMPTION	67,60 kWh
SYSTEM MONTHLY ELECTRICITY CONSUMPTION	36.504 kWh
SYSTEM MONTHLY ELECTRICITY BILL	3.427,72 \$
TOTAL INVOICE PAID MONTHLY	3.427,72 \$

**TECHNICAL DATA BEFORE HIGH-PRESSURE HUMIDIFICATION UNIT**

HUMIDIFICATION UNIT ELECTRICITY CONSUMPTION	2,20 kWh
HUMIDIFICATION UNIT MONTHLY ELECTRICITY CONSUMPTION	1.188 kWh
HUMIDIFICATION UNIT MONTHLY ELECTRICITY BILL	111,55 \$
HUMIDIFICATION UNIT WATER CONSUMPTION	660 lt/h
HUMIDIFICATION UNIT MONTHLY WATER CONSUMPTION	356,4 m <sup>3</sup>
HUMIDIFICATION UNIT MONTHLY WATER BILL	561,97 \$
TOTAL INVOICE PAID MONTHLY	673,52 \$

**GAIN AMOUNTS AFTER HIGH-PRESSURE HUMIDIFICATION UNIT**

MONTHLY EARNINGS AFTER HUMIDIFICATION UNIT	2.754,2 \$
HUMIDIFICATION UNIT SELF COST RECOVERY TIME	≤4 Ay

# Evaporative Humidifier

Evaporative humidification and cooling is generally the process of lowering, humidifying and reducing the ambient temperature by bringing hot and dry air into contact with water.

Technowell Evaporative humidifications and coolers have large surface cooling and humidification pads. Pads stay wet continuously with the water flowing through the channels. The hot, dry air brought inside comes into contact with the moving water as it moves through the pads, thanks to the powerful and quiet fan. Heat transfer occurs between air and water during the passage of air. Cool and humid air is given to the environment to be cooled. The natural evaporation process provides a comfortable working atmosphere by providing fresh and cold air



# Advantages

- Provides 100% fresh air and optimum cooling.
- Provides humidification in the indoor environment.
- It consumes 90% less energy than gas systems.
- Installation cost is 50% cheaper than system air conditioners.
- There is no compressor unit, maintenance costs are low.
- It is an environmentally friendly cooler, it does not emit any harmful gas to the environment.
- Evaporative coolers filter bacteria, dust, pollen, and fumes from the outside air, resulting in cleaner and healthier indoor air.
- Unlike gas air conditioners, evaporative coolers do not dry the surrounding air.
- Evaporative coolers provide fresh air at all times and humidify the environment by providing air circulation.
- The mounting position can be easily changed if desired.



# Areas of Usage



**Air Handling Units**



**Warehouses**



**Textile Factories**



**Bakeries**



**Carpet Factories**



**Industrial Kitchens**



**Glass Production Facilities**



**Indoor Sports Halls**



**Power Plants**



**Animal Farms**



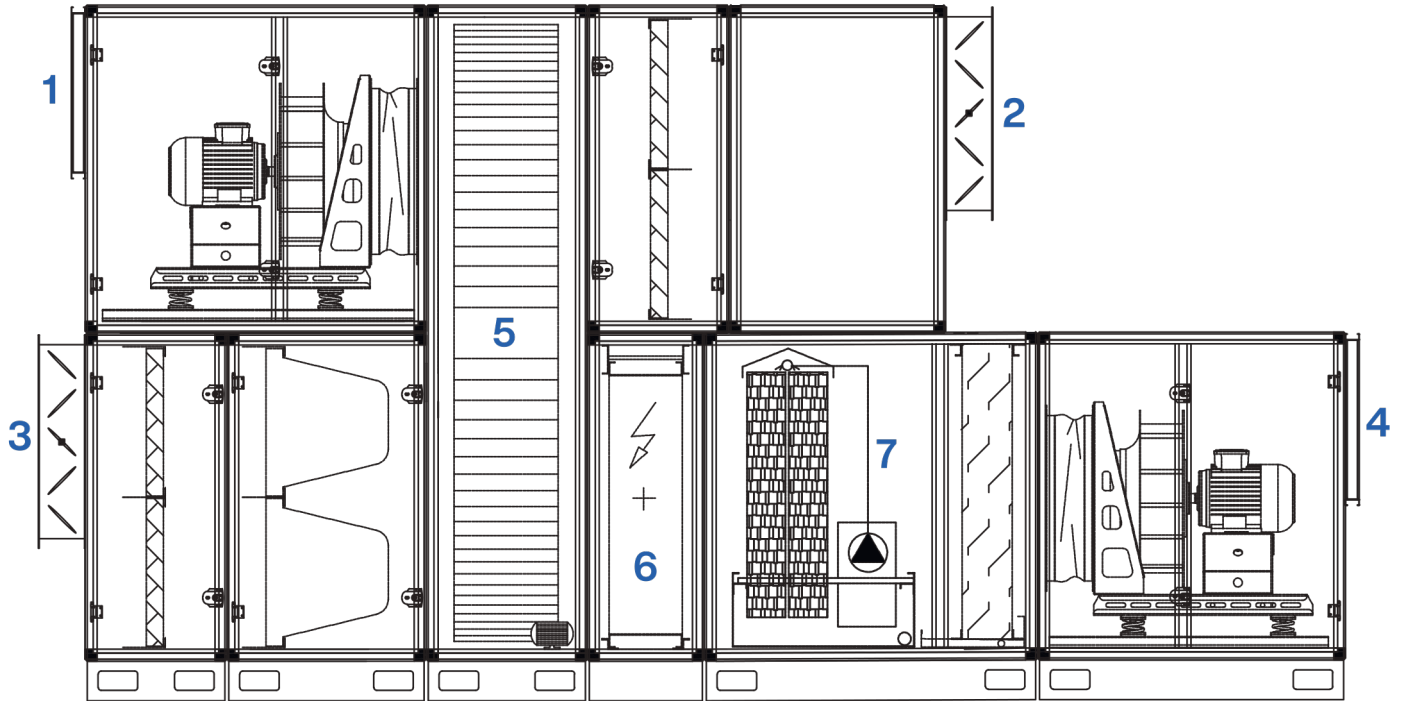

- ① **Inside Air Exhaust**
- ② **Inside Air Suction**
- ③ **Fresh Air Inlate**
- ④ **Inside Air Outlet**
- ⑤ **Rotary Type Heat Recovery Unit**
- ⑥ **Heating Coil**
- ⑦ **Evaporative Cooling**



Type 7090

Type 5090

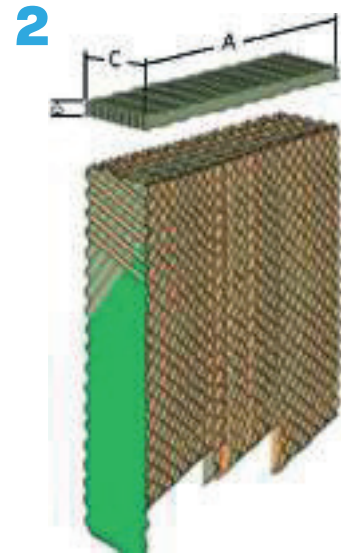
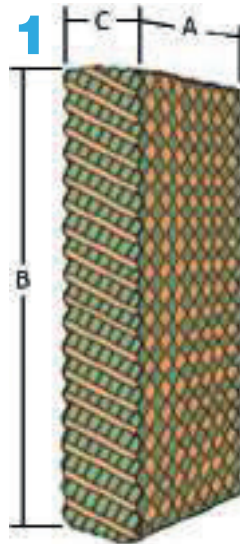
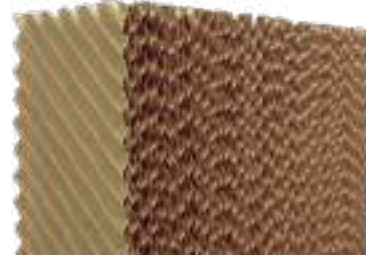
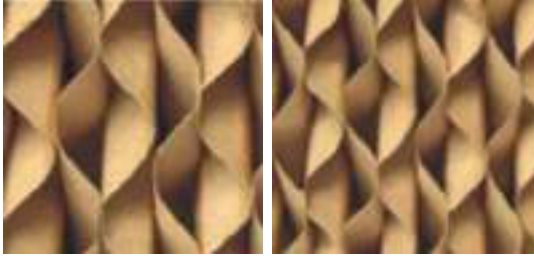

	Standard Heights	Standard Width	Standard Depths
<b>1</b> Evaporative Heat Exchanger	B: 1500 mm - 2000 mm	A: 600 mm	C: 100 mm - 150 mm
<b>2</b> Water Distribution Pad	D: 30 mm	A: 600 mm	C: 100 mm - 150 mm

Heat exchanger when high efficiency is required depth may vary, contact Technowell for information.

# HONEYCOMB EFFICIENCY AND AIR SIDE PRESSURE DROP

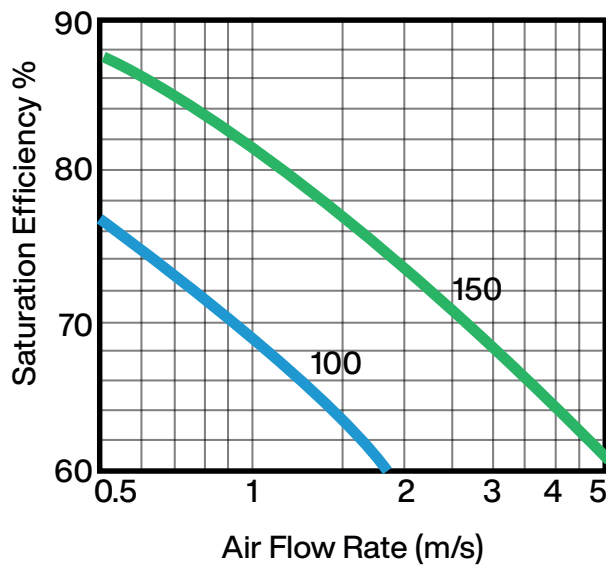

Please contact Technowell for heat exchangers of different depths (efficiency).

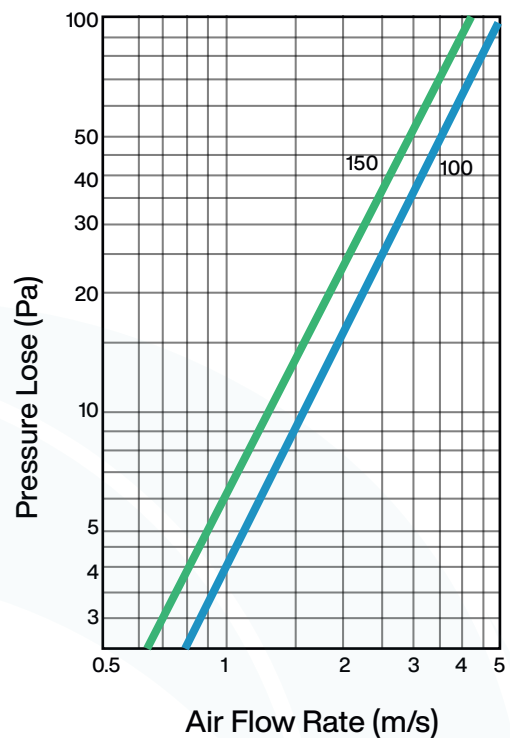

# Ultrasonic Humidifier

With the help of the oscillator used by the Technowell ultrasonic humidifier introduces water particles smaller than 10 m (3-5 m on average) into the air to increase ambient humidity by creating a more balanced moisture environment.

It is easy to use due to its automatic water level control. Its low noise level, electronically controlled device and high humidity capability set it apart.

Ultrasonic humidifiers are suitable for use in many industries.



## Features

- Digital control LED display
- Droplet size less than 10  $\mu\text{m}$  (3-5  $\mu\text{m}$  on average)
- 25% - 95% humidity control
- Automatic water level warning
- Automatic water filling
- 8000 hours oscillator life
- Low maintenance cost
- Digital Control LED Display
- Dry contact connection
- Custom stainless steel enclosures can be manufactured upon request.
- Our models can be custom-made without a display, humidity sensor, or feet upon request. (WP Model)



# Areas of Usage



Textile



Laboratory



Computer Rooms



Tobacco



Electronic



Cold Storage



Plastic



Food



Paint Shops



Germination Room



Printing Press



Botanical



MODEL	TWH-4-SP	TWH-8-SP	TWH-12-SP	TWH-16-SP
	TWH-4-WP	TWH-8-WP	TWH-12-WP	TWH-16-WP
CAPACITY (25 °C – 30%RH)	4 lt/h	8 lt/h	12 lt/h	16 lt/h
POWER SUPPLY	220V - 50 Hz	220V - 50 Hz	220V - 50 Hz	220V - 50 Hz
OPERATION CURRENT	2,1 A	3,9 A	5,6 A	7,3 A
FLOW RATE	136 m <sup>3</sup> /h	136 m <sup>3</sup> /h	440 m <sup>3</sup> /h	440 m <sup>3</sup> /h
FLOW RATE (1 MT PIPE)	121 m <sup>3</sup> /h	121 m <sup>3</sup> /h	362 m <sup>3</sup> /h	362 m <sup>3</sup> /h
FLOW RATE (1 MT 90° ELBOW PIPE)	109 m <sup>3</sup> /h	109 m <sup>3</sup> /h	300 m <sup>3</sup> /h	300 m <sup>3</sup> /h
FLOW RATE (5 MT 90° ELBOW PIPE)	99 m <sup>3</sup> /h	99 m <sup>3</sup> /h	286 m <sup>3</sup> /h	286 m <sup>3</sup> /h
OPERATING TEMPERATURE	1°C - 50 °C	1°C - 50 °C	1°C - 50 °C	1°C - 50 °C
NOISE LEVEL	≤ 45 dB(A)	≤ 45 dB(A)	≤ 50 dB(A)	≤ 50 dB(A)
CONNECTION DIAMETER	Ø 110 mm	Ø 110 mm	Ø 110 mm x 2 Pieces	Ø 110 mm x 2 Pieces
WATER TANK CAPACITY	18 lt	18 lt	25 lt	25 lt
NET WEIGHT	25,5 kg	28,0 kg	38,5 kg	41 kg
CONNECTION	Dry Contact	Dry Contact	Dry Contact	Dry Contact
CASE TYPE	Electrostatic Powder Coated (RAL9002)	Electrostatic Powder Coated (RAL9002)	Electrostatic Powder Coated (RAL9002)	Electrostatic Powder Coated (RAL9002)
CASE DIMENSIONS	300x600x440 mm	300x600x440 mm	460x630x540 mm	460x630x540 mm
OSCILLATOR LIFE	8000 h	8000 h	8000 h	8000 h

# PRODUCT CAPACITY CURVES

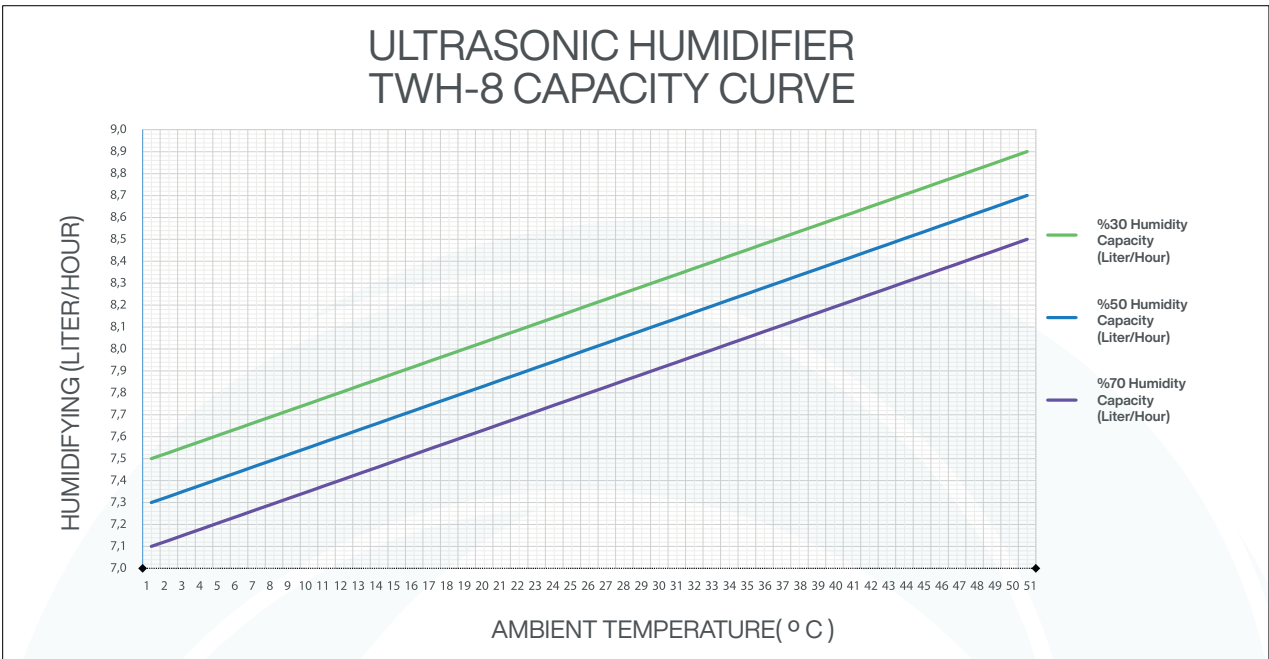
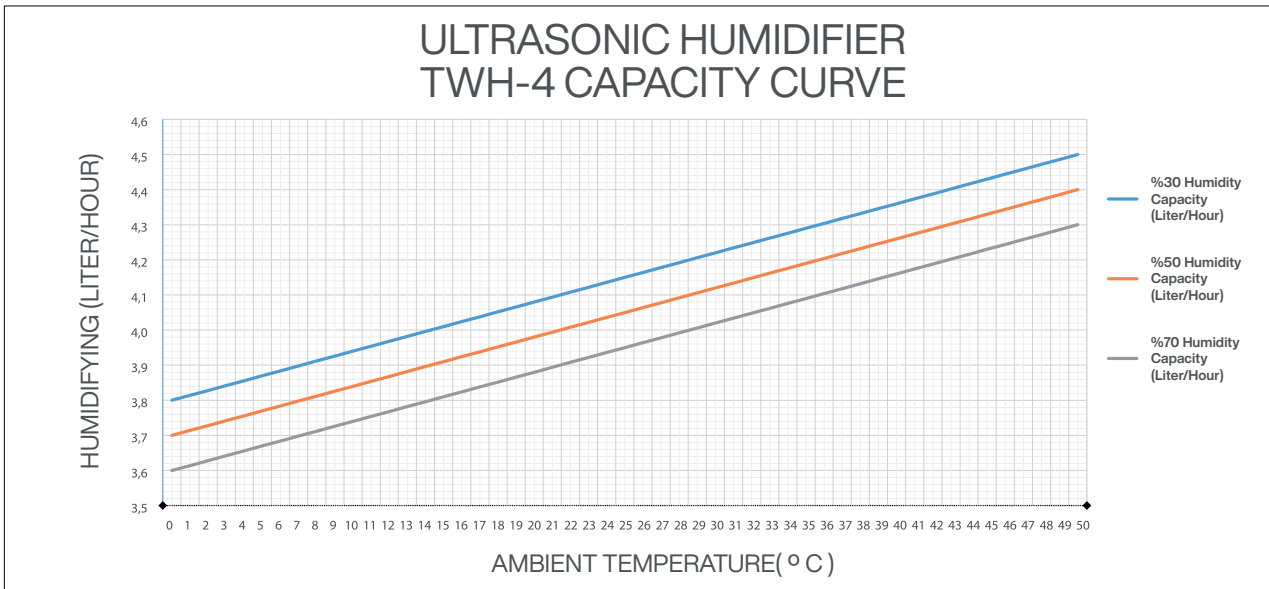

# PRODUCT CAPACITY CURVES

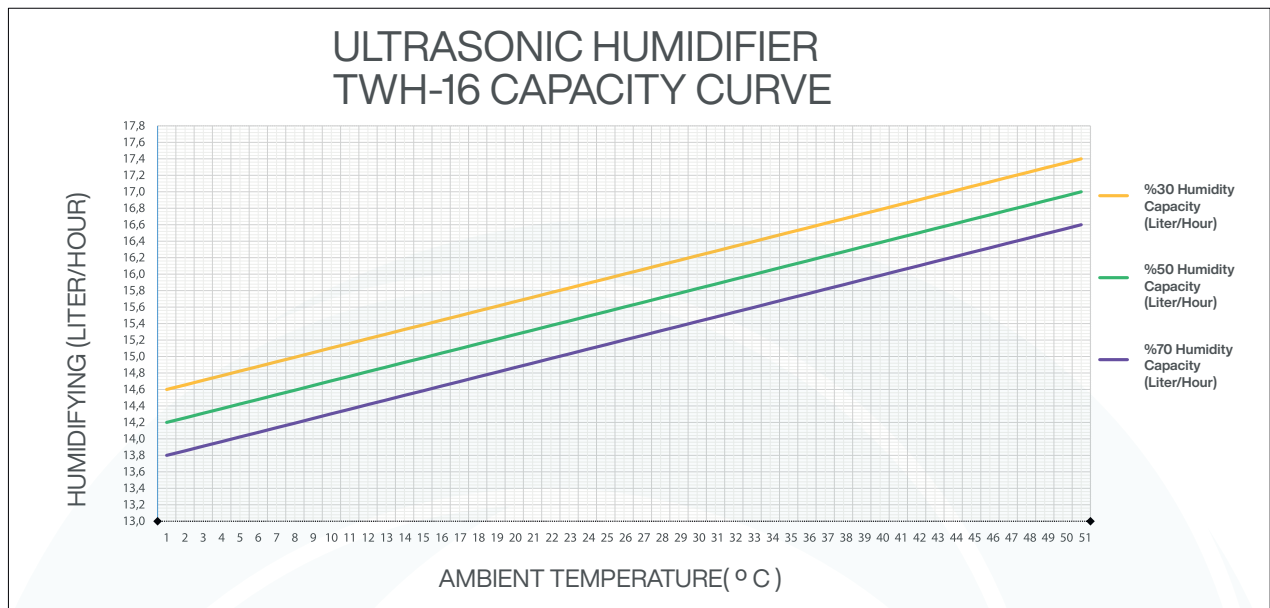
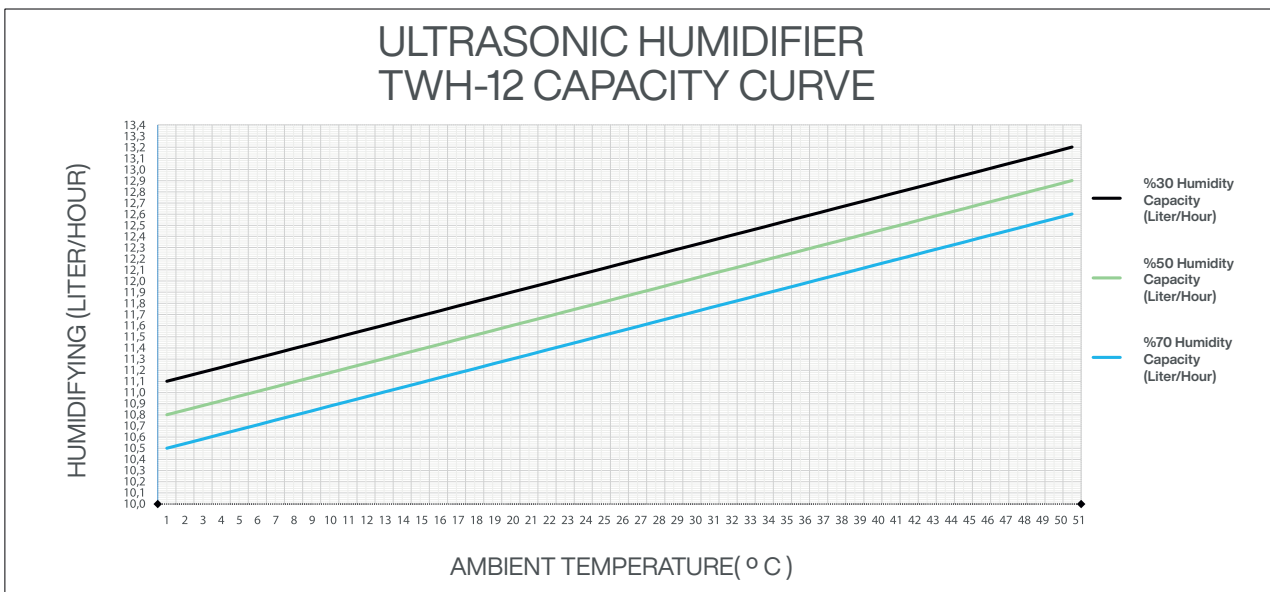

**technowell**

[technowell.com.tr](http://technowell.com.tr)